

Reception Teacher's Handbook Phase Four Assessments

Contents

Phase Two Letter recognition and recall check	1
Phase Three Grapheme recognition and recall check	2
Blending check	3
Blending check analysis sheet	4
Reading tricky words check	5
Reading tricky words check analysis sheet	6
Segmenting check	7
Segmenting check analysis sheet	8
Spelling tricky words check	9
Letter formation check	10
Group letter formation record sheet	11
Phase Four Summative assessment record sheet	12

Phase Two Letter recognition and recall check

There are two parts to this assessment. Check the child can do the following:

- 1 Give the letter sound when you point to each letter.
- 2 Point to the letter when you say each letter sound.

s a t p

i n m d

g o c k

ck e u r

h b f l

ff ll ss

Phase Three Grapheme recognition and recall check

There are two parts to this assessment. Check the child can do the following:

- 1 Give the sound when you point to each grapheme.
- 2 Point to the grapheme when you say each sound.

j v w x y

z zz qu ch sh

th ng ai ee igh oa

oo ar or ur ow

oi ear air er

Blending check

Ask the child to say the sounds and blend them to read each word.

dent

slam

gust

drop

twist

droop

flight

burst

frown

spoil

Blending check analysis sheet

Name: _____

Date: _____

Tick to show whether the child's response is correct or incorrect. Record any inaccuracies in the comments box.

Word	Correct	Incorrect	Comments
dent			
slam			
gust			
drop			
twist			
droop			
flight			
burst			
frown			
spoil			

Reading tricky words check

Ask the child to read these tricky words.

some	one
said	come
do	so
were	when
have	there
out	like
little	what

Reading tricky words check analysis sheet

Name: _____ Date: _____

Tick to show whether the child's response is correct or incorrect. Record any inaccuracies in the comments box.

Word	Correct	Incorrect	Comments
some			
one			
said			
come			
do			
so			
were			
when			
have			
there			
out			
like			
little			
what			

Segmenting check

Say the word that goes with each picture. Ask the child to say the word in sound-talk and then write the letters in the phoneme frame. Alternatively, the child could write the words on a separate piece of paper.

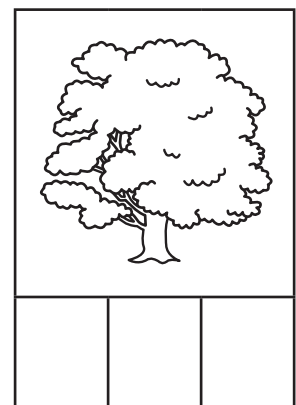
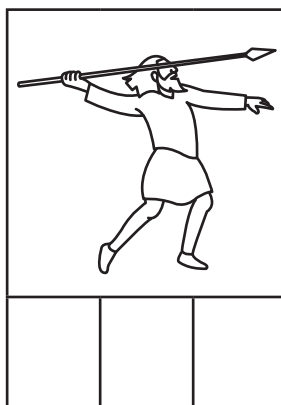
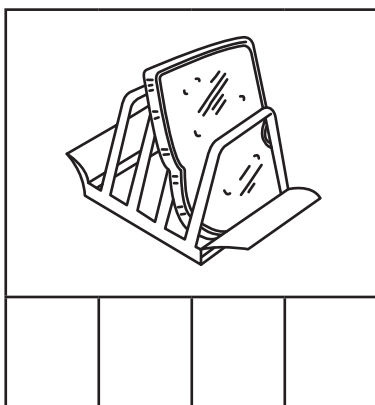
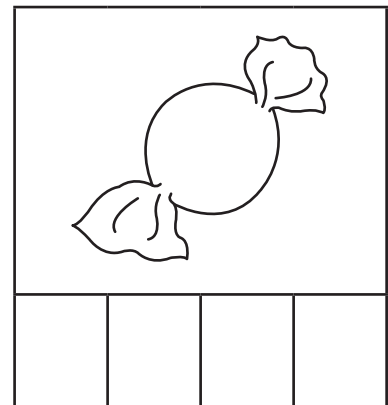
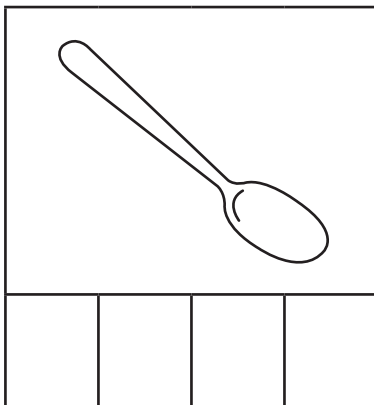
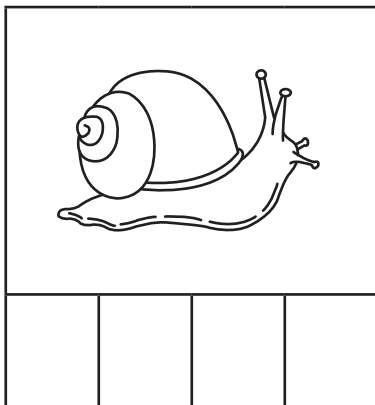
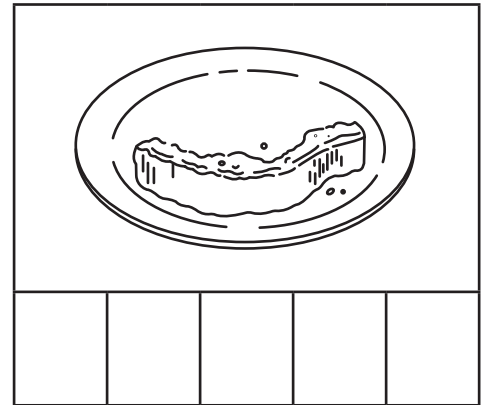
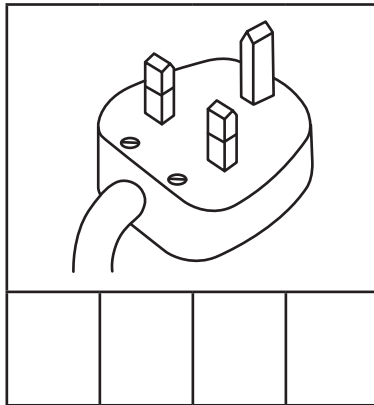
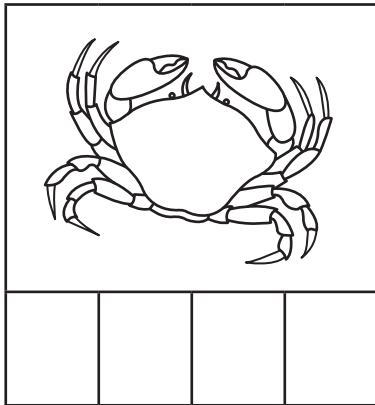
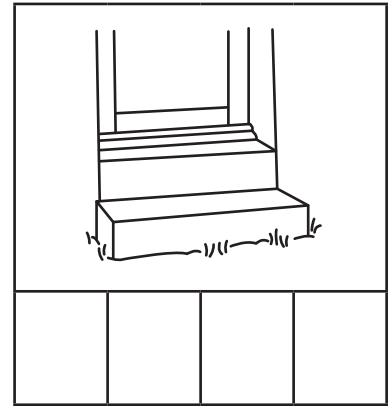
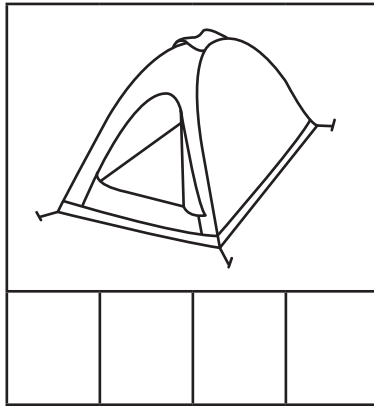
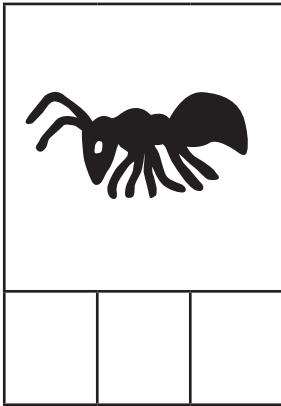

Segmenting check analysis sheet

Name: _____ Date: _____

For each assessment, tick to show whether the child's response is correct or incorrect. Record any inaccuracies in the comments box.

Word	Correct	Incorrect	Comments
ant			
tent			
step			
crab			
plug			
crust			
snail			
spoon			
sweet			
toast			
spear			
tree			

Spelling tricky words check

Name: _____

Date: _____

Say each of the tricky words below and ask the child to write it on their whiteboard or on paper.

Word	Correct	Incorrect	Comments
he			
she			
we			
me			
be			
was			
my			
you			
her			
they			
all			
are			

Letter formation check

Name: _____

Date: _____

Say the name of each letter in the alphabet and ask the child to write it. Watch how the child forms each letter.

After the assessment, tick the letters that are formed correctly. Use the comments box to make a note of errors in formation (for example, letters formed in the wrong direction).

_____	_____	_____	_____
_____	_____	_____	_____
_____	_____	_____	_____
_____	_____	_____	_____
_____	_____	_____	_____
_____	_____	_____	_____
_____	_____	_____	_____
_____	_____	_____	_____

Group letter formation record sheet

Tick to show which letters the child formed correctly. Use the comments box to note errors in formation (for example, letters formed in the wrong direction).

Name and date										
a										
b										
c										
d										
e										
f										
g										
h										
i										
j										
k										
l										
m										
n										
o										
p										
q										
r										
s										
t										
u										
v										
w										
x										
y										
z										
Comments										

Phase Four Summative assessment record sheet

Tick or date the appropriate box if it is achieved. Dot to show it is partially achieved.

Name and date																																																									
Can give the sound for each letter																																																									
Can give the sound for Phase Three graphemes																																																									
Can find each letter for a given sound																																																									
Can find the Phase Three grapheme for each sound																																																									
Can blend and read words with adjacent consonants																																																									
Can segment and spell words with adjacent consonants																																																									
Can read Phase Four tricky words																																																									
Can spell Phase Four tricky words																																																									
Can write each letter mostly correctly																																																									